

## Model 110

### Standard-Flow Spray Valve

- Sprays low- to medium-viscosity fluids (lower than 10,000 cP)
- All wetted components are stainless steel, Teflon<sup>®</sup>, or Kalrez<sup>®</sup> for compatibility with a greater number of fluids
- Easy adjustment of material flow for greater dispensing accuracy and less material waste
- Interchangeable flat or round spray cap
- Spray range of 0.25" (6.35 mm) to greater than 2" (50.8 mm)
- Compatible with most standard fluid packages and delivery systems
- Pneumatically operated - no electrical power required
- Sealed fluid body with no exposure to ambient facilitates easy shutdown and cleanup
- Includes a 0.375" (9.53 mm) OD tube-to-elbow, swivel material fitting to maximize and optimize the material flow rate

The Dymax Model 110 standard-flow spray valve is a unique, normally closed, stainless steel needle valve. This valve uses air pressure to atomize fluids and transfer them to a substrate. The valve has a dual-acting air cylinder that provides immediate start/stop functionality as well as a stroke adjustment, which can be used to fine tune the flow rate of the valve. The valve can be used in a wide variety of coating applications, applying any number of low- to medium-viscosity fluids including solvents, conformal coatings, protective coatings, masking resins, and lubricants generally lower than 10,000 cP.

The spray valve can be fitted with numerous accessories to customize the valve for the user's application. Compatible with numerous styles of material reservoirs, this spray valve can dispense materials from a variety of different packages. The standard model is fitted with a round spray cap that provides a circular spray pattern, but an optional flat spray cap is available if a linear or flat spray pattern is preferred. A pneumatic trigger gun assembly is also available for this valve, allowing users to have manual control over the valve and its spray.

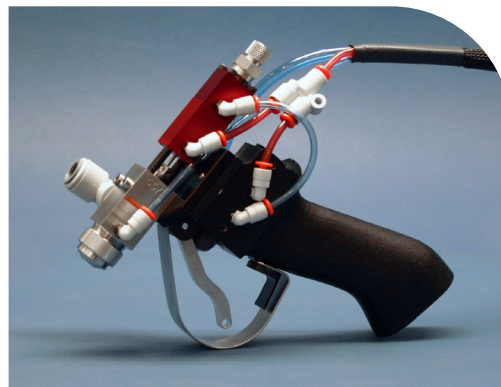

Model 110 Spray Valve with Gun Accessory

Specifications	
Part Number	T18429 Standard-flow spray valve, round cap
Valve Type	Normally closed, needle valve
Construction Materials	Body: stainless steel, aluminum Wetted Parts: 303 & 304 stainless steel, Teflon®, Kalrez®
Operating Air Pressure	60-100 psi [4.14 - 6.89 bar]
Activation, Air	2-position, 4-way air solenoid valve
Maximum Inlet Fluid Pressure	2,500 psi [172.37 bar]
Atomizing Air Consumption	1.5 cfm at 10 psi and 0.1 cfm thereafter for every 1 psi increase
Viscosity Range	1 - 10,000 cP
Spray Pattern Width	Flat 0.75" - 2+" [1.91 cm - 5.08+ cm] Round 0.25" - 2" [0.64 cm - 5.08 cm]
Dimensions (W x H x D)	0.87" x 0.87" x 5.80" [2.2 cm x 2.2 cm x 14.7 cm]
Weight	9 oz [0.26 kg]
Unit Warranty	1 year from purchase date, excluding soft seals
Recommended Accessories	T15697 Flat Spray Cap
Spare Parts	T15696 Standard-Flow Spray Valve Rebuild Kit

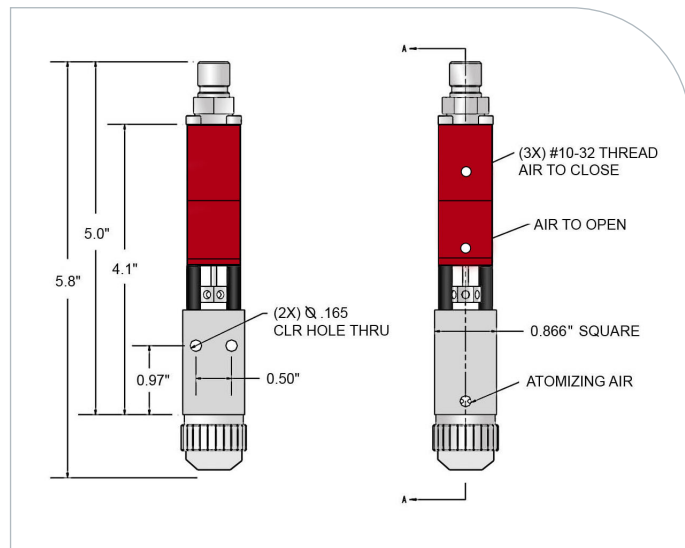

[www.dymax.com](http://www.dymax.com)

#### Americas

USA | +1.860.482.1010 | [info@dymax.com](mailto:info@dymax.com)

#### Europe

Germany | +49 611.962.7900 | [info\\_de@dymax.com](mailto:info_de@dymax.com)  
Ireland | +353 21.237.3016 | [info\\_ie@dymax.com](mailto:info_ie@dymax.com)

#### Asia

Singapore | +65.67522887 | [info\\_ap@dymax.com](mailto:info_ap@dymax.com)  
Shanghai | +86.21.37285759 | [dymaxasia@dymax.com](mailto:dymaxasia@dymax.com)  
Shenzhen | +86.755.83485759 | [dymaxasia@dymax.com](mailto:dymaxasia@dymax.com)  
Hong Kong | +852.2460.7038 | [dymaxasia@dymax.com](mailto:dymaxasia@dymax.com)  
Korea | +82.31.608.3434 | [info\\_kr@dymax.com](mailto:info_kr@dymax.com)